



# **TECHNICAL BULLETIN 98**

## **DESIGN GUIDELINES**

### **MODEL EMA**

#### **ELECTRIC MULTIPLE DISC CLUTCHES and BRAKES**

*The Carlyle Johnson Machine Company, LLC  
291 Boston Turnpike • P.O. Box 9546 • Bolton, CT 06043-9546  
(860) 643-1531 • Toll-free (888) - MAXITORQ  
[www.cjmco.com](http://www.cjmco.com) • e-mail : [maxitorq@cjmco.com](mailto:maxitorq@cjmco.com)*



# The Carlyle Johnson Machine Company, LLC

## Model EMA Electric Multi-Disc Clutches

### CONTENTS

1	Introduction	
1.1	About Carlyle Johnson .....	2
1.2	Related Publications.....	2
1.3	How to Contact Carlyle Johnson .....	2
2	Design Guidelines – Mechanical	
2.1	Mounting.....	3
2.2	Alignment.....	3
2.3	Anti-rotation Strap.....	3
2.4	Dry vs. Oil Bath.....	3
2.5	Constant-slip Applications .....	4
2.6	Neutral Drag .....	4
2.7	Clutch Drive Cups.....	4
2.8	Clutch to Drive Cup Relationship.....	4
2.9	Backlash.....	4
3	Design Guidelines – Electrical	
3.1	Power Supply .....	5
3.2	Voltage / Over Energization.....	5
3.3	Electrical Connections .....	5
3.4	Fuses.....	5
3.5	Arc Suppression	
	Using a Resistor for Arc Suppression.....	6
	Using a Capacitor or Zener Diode for Arc Suppression.....	7
	Using a Diode for Arc Suppression.....	7
4	Operating Parameters	
4.1	Torque Ratings .....	8
4.2	Engagement / Disengagement Times .....	8
4.3	Cycle Rate.....	8
4.4	Rotation / Speed.....	8
4.5	Inertia.....	8
	Charts	
	Static Torque vs Input Voltage.....	Chart 1
	Tables	
	Clutch Mechanical Data .....	Table 1
	Clutch Electrical Data .....	Table 2
	Figures	
	Typical Applications .....	Figure 1
	Exploded Parts Diagram – EMA clutch .....	Figure 2
	Formulas for sizing Clutch/Brake	
	Torque based on Inertia and Time.....	Appendix 1
	Torque based on Drive Components.....	Appendix 1
	Formula for determining Heat Load.....	Appendix 1
	Sample Calculations.....	Appendix 2
	Tables : Inertia of Round Steel Cylinders, Shafts, Discs, or Bars.....	Appendix 3
	Other Useful Formulas - Torque and Inertia .....	Appendix 4

# The Carlyle Johnson Machine Company, LLC

## Model EMA Electric Multi-Disc Clutches

### DESIGN GUIDELINES

#### 1 Introduction

##### 1.1 About Carlyle Johnson

Carlyle Johnson manufactures clutches, brakes, torque limiters, overload release clutches, fail-safe brakes, and power take-off packages for many applications. Electric, mechanical, pneumatic, and hydraulic powered clutches are available. From submarines to the Space Shuttle; military armored vehicles to commercial aircraft; machine tools to medical devices; packaging machines to printing presses; oil drilling equipment to rocket launchers; and hundreds of other applications where power-transmission equipment is installed, Carlyle Johnson Maxitorq® clutches and brakes provide long-life and trouble-free service. Original Equipment Manufacturers have known for almost 100 years that their products will perform better and more reliably if Carlyle Johnson Maxitorq® power transmission products are specified.

This bulletin deals with the model EMA electric clutches and brakes, a family of devices which can handle torque from as little as 10 lb-ft to over 2,000 lb-ft. Nine standard models cover this range. Many special designs have also been created to solve specific problems outside the performance of our catalog standards.

Maximum life of EMA clutches and brakes can be achieved with careful attention to size, installation, and application. This publication details the technical characteristics of the Maxitorq® model EMA devices. Engineering and applications personnel at Carlyle Johnson are always available to provide additional data, assist in applications, and suggest solutions to unique or difficult power transmission design problems. You may contact the factory toll-free at 1-888-MAXITORQ (1-888-629-4867) between 8:00 A.M. and 5:00 P.M. Eastern Time, during normal workdays, for technical assistance, pricing, and delivery information.

##### 1.2 Related Publications

Clutch Dimensions, etc. Brochure “Maxitorq® Electric Multiple Disc Clutches and Brakes – Model EMA” available from Carlyle Johnson or your authorized Representative / Distributor

Clutch Maintenance and Repair Booklet “Maxitorq® Model EMA Electric Multiple Disc Clutch – Maintenance / Repair / Troubleshooting Manual” available from Carlyle Johnson

##### 1.3 How to contact Carlyle Johnson

Carlyle Johnson may be reached from 8:00 A.M. to 5:00 P.M. in the Eastern Time Zone of the United States, during normal workdays.

Telephone: 1 - (860) 643-1531 Option “3” SALES then select from the following:

Option “1” for Spare Parts

Option “2” for Applications Engineering

Option “3” for Government and Aerospace products

Option “4” for International Sales

Toll-Free: 1 - (888) 629-4867 (1 - 888 - MAXITORQ) - same options as above

Internet: <http://www.cjmco.com>

e-Mail: [maxitorq@cjmco.com](mailto:maxitorq@cjmco.com)

Mail: 291 Boston Turnpike, PO Box 9546, Bolton, CT 06043-9546

FAX: 1 - (860) 646-2645

# The Carlyle Johnson Machine Company, LLC

## Model EMA Electric Multi-Disc Clutches

### DESIGN GUIDELINES

## 2 Design Guidelines – Mechanical

### 2.1 Mounting

Model EMA clutches are designed to be mounted on a finished shaft with a key to transmit torque. The clutch must be secured axially.

There is no provision within the clutch itself to secure it to the shaft. Typically, the ends of the clutch are set against either a shoulder in the shaft, a spacer, a retaining ring, a shaft collar or clamping screw if mounted on the shaft end.

The drive cup is mounted on some type of power transmission component such as a pulley, sheave, sprocket, gear, or a coupling hub if used as a clutch coupling or to a frame member if used as a brake. As a clutch, the power transmission component must be separated from the shaft with an anti-friction bearing suitable to the application.

The proper distance between the clutch and the drive cup must be maintained. See Figure 1 for a typical clutch application.

### 2.2 Alignment

The drive cup and the clutch body must be held concentric within .005 TIR. One design approach which will assure this concentricity is the use of an alignment bearing as shown in Figure 1. The bearing and drive cup adapter are supplied by the customer or are available from Carlyle Johnson as an optional accessory; they are not included in the standard catalog clutch configuration.

See Table 1 and Figure 1 for tolerance on axial position by clutch model.

If an alignment bearing is not used, care must be taken during design to maintain both the cup-to-housing dimension, as well as their concentricity and angular displacement.

### 2.3 Anti-rotation Strap

The stationary coil housing assembly contains an NPT nipple which is to be used both as an attachment for electrical conduit, and an anti-rotation strap. Models EMA0265 and EMA0325 has a 3/8" NPT straight thread. Models EMA0375 through EMA1150 have 1/2" NPT straight threads. See Figure 1 for a typical installation.

Even though the clutch housing is mounted on ball bearings, some bearing torque may be transmitted into the housing assembly due to rotation, particularly at low temperatures. The electrical lead wires are not capable of serving as an anti-rotation device.

Care must be taken to assure that the anti-rotation strap does not load the clutch and drive cup bearings, which would lead to excessive wear and may cause premature failure.

### 2.4 Dry vs. Oil Bath

Maxitorq® clutches can be run either dry or in an oil bath. If the clutch is run in oil, the oil must not contain any extreme pressure additives. Extreme pressure additives will degrade the clutch's ability to transmit torque.

The use of ATF oils such as Dexron II are recommended for oil-bathed applications.

Table 1 "Mechanical Characteristics" shows the RPM limits for dry clutch applications. Contact the factory for RPM limitations when clutches are run in oil.

# The Carlyle Johnson Machine Company, LLC

## Model EMA Electric Multi-Disc Clutches

### DESIGN GUIDELINES

#### 2.5 Constant-slip Applications

Maxitorq® clutches are not designed to be run in constant-slip applications, whether run dry or in oil.

#### 2.6 Neutral Drag

A small amount of torque is transmitted in the neutral or “disengaged” position. This is normal for multi-disc clutches.

At very low speeds, up to 2% of the rated static torque may be transmitted in dry applications. This value will fall to 1% or less at high speeds.

#### 2.7 Clutch Drive Cups

Carlyle Johnson can supply internal or external flange drive cups. See Figure 2 for typical illustrations. Special design drive cups can also be engineered and produced.

Wherever possible, ball bearings are recommended to support drive cups and assure good clutch/drive cup alignment. If oil impregnated bronze bearings are used, ample flange area on the bearing must be provided to take any end thrust between the drive cup and clutch body which may be transmitted by the power transmission components.

#### 2.8 Clutch to Drive Cup Relationship

Torque is transmitted from the lugs on the Outer Discs to the clutch cup, or, if the clutch is reversed, from the Drive Cup to the lugs on the Outer Disc. Care should be taken to make certain that the cup engages all of the Outer Discs uniformly.

In addition, the clutch cup “fingers” must not contact the Buttress Plate. Figure 1 shows the typical clearance between the cup fingers and the Buttress Plate.

Alignment between the cup and clutch is critical. The clearances noted in Figure 1 (approximately 1/16”) must be maintained uniformly around the entire circumference of the cup.

Note that “Axial Position” shown in Figure 1 and tabulated in Table 1 – “Mechanical Characteristics” varies with the clutch/cup size, and assumes the use of Carlyle Johnson standard drive cups. If non-Carlyle drive cups are used, this dimension may not be correct. Contact the factory for assistance.

#### 2.9 Backlash

Backlash in Model EMA clutches is approximately 2°. Table 1 – “Mechanical Characteristics” shows the theoretical backlash in the EMA Maxitorq® family of clutches based on measurements made at the factory. Carlyle Johnson produces other designs of clutches which have essentially zero backlash. Contact the factory for more information on these models.

# The Carlyle Johnson Machine Company, LLC

## Model EMA Electric Multi-Disc Clutches

### DESIGN GUIDELINES

#### 3 Design Guidelines – Electrical

##### 3.1 Power Supply

Performance data in Table 2 “Electrical Characteristics” were derived using a standard Carlyle Johnson Model CEC Power Supply. Other power supply sources may yield less favorable clutch performance figures.

Switching should be done on the DC positive ( + ) leg of the circuit. Suitable suppression is incorporated into the circuit of the Carlyle Johnson CEC Power Supply to provide acceptable switch life.

Carlyle Johnson has special power supply designs to enhance the performance of the clutch. Soft start power supplies, and over-energizing power supplies can be used for slower or quicker clutch engagement. For power savings, reduced holding voltage power supplies are available, as are special power supplies to meet your specific needs. Contact the factory for information.

Caution is advised when cycling the clutch directly from a PLC output or other electrically sensitive device. The inductance of the clutch coil is extremely high, as are inrush and outrush currents. Contact the factory for assistance in power supply selection when over-energizing the clutch or using a PLC for clutch power.

Table 2 shows the power draw for EMA clutches.

##### 3.2 Voltage / Over Energization

Standard EMA Maxitorq® clutches are provided with either 24 or 100 volt DC coils. Other voltages are available - Carlyle Johnson stocks coils with voltages ranging between 12 to 240 volts DC. Please contact the factory for information.

Voltage supplied to the clutch must be within 10% of the coil rating to achieve the rated torque transmission.

The clutch may be momentarily over-energized to achieve faster engagement time. A voltage of 150% of the nominal coil voltage may be applied for not more than one second. All other considerations in the design – power supply, fuses, etc., must be resized to accommodate this behavior. The data in Table 2 assumes normal voltage  $\pm 10\%$ .

Output torque is a function of voltage applied. However, approximately 40% of the nominal rating of the coil is required to overcome the separator springs and allow torque to be transmitted.

##### 3.3 Electrical Leads

Clutches are supplied with lead wires which protrude through the coil housing in a fitting that has a standard NPT straight thread. The typical length of these leads is 30”. There is no polarity to the leads – either one may be considered positive ( + ).

When making electrical connections, follow NEC standards and/or other governing electrical codes.

##### 3.4 Fuses

Fuses must be capable of tolerating 135% of the nominal clutch power draw. Fuse recommendations are contained in Table 2 – Electrical Characteristics. These values represent normal application of Model EMA clutches. Buss AGC series fuses will provide the proper inrush/outrush current protection.

Clutches subject to overenergization will require fuses with a higher current tolerance.

The fuse protects upstream equipment – such as the power supply – not the clutch. Design considerations must include the effect of a potential coil short circuit, should one occur.

# The Carlyle Johnson Machine Company, LLC

## Model EMA Electric Multi-Disc Clutches

### DESIGN GUIDELINES

#### 3.5 Arc Suppression

The clutch coil acts as a large inductor in the control circuit. When deenergized, a reverse voltage spike is generated by the clutch coil and transmitted back through the clutch circuit. This reverse voltage spike can be very high, and unless suppressed, can cause damage to the switch and/or coil.

There are three types of arc suppression commonly used. Their application and effect on disengagement speed are as follows:

*Resistor or Varistor* - used for normal disengagement speed

*Capacitor or Zener Diode* - used for fast disengagement speed

*Diode* - Used for slow disengagement speed, and when arcing is to be completely eliminated.

#### Using a Resistor for Arc Suppression

For most applications, a simple resistor connected in parallel with the clutch coil will suffice (see Schematic 1 below). The value of the resistor should be five to six times the coil resistance (see Table 2 at the back of this Bulletin for coil resistance values). The resistor should be rated for wattage equal to about 25% of the coil's power rating (see Table 2).

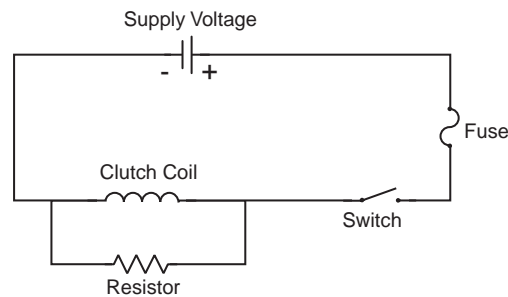

SCHEMATIC 1

To eliminate the power dissipated by the resistor while the clutch is energized, a varistor alone or a diode in series with the resistor may be used (See Schematics 2 and 3). For a 100-volt coil, use a 1N5402 diode with a 200 PIV rating, and for a 24-volt circuit, use a 1N5401 diode with a 100 PIV rating. The varistor should be equivalent to a Siemens S14K35 (24-volt coil) or equivalent to a Siemens S14K275 (100-volt coil).

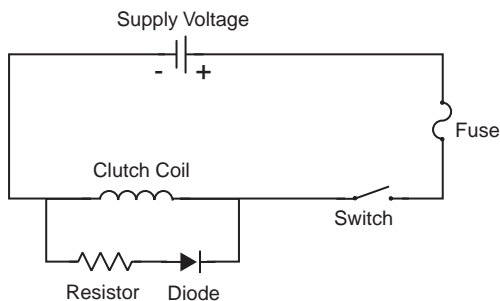

SCHEMATIC 2

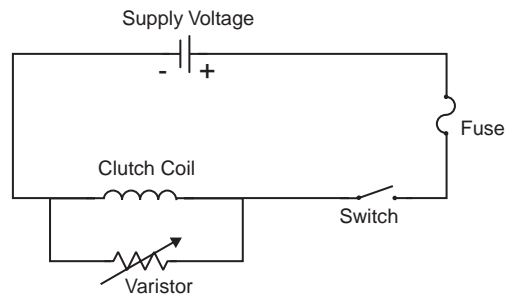

SCHEMATIC 3



# The Carlyle Johnson Machine Company, LLC

Model EMA Electric Multi-Disc Clutches

## DESIGN GUIDELINES

### Using a Capacitor or Zener Diode for Arc Suppression

For applications that require a fast clutch or brake disengagement, a capacitor in series, or transient suppressor zener diodes should be connected in parallel with the clutch coil (See Schematics 4 and 5).

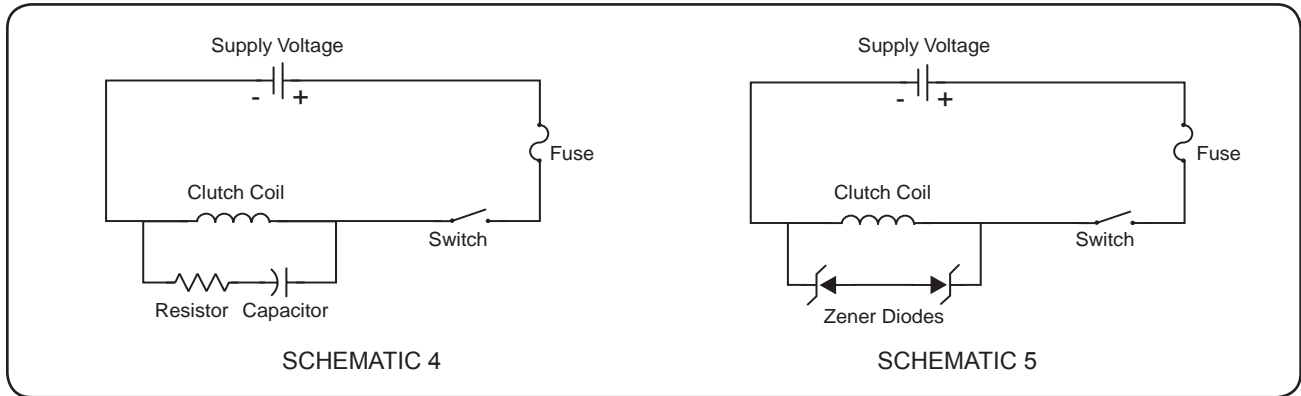

The capacitor used must be bipolar such as a motor starter capacitor. When a capacitor larger than 50 mfd. in a 24-volt circuit, or 7 mfd. in a 100-volt circuit is used for arc suppression, a resistor should be connected in series with it. This is required in order to limit the capacitor charging current, so that the switch or power supply will not be overloaded. The resistor should be approximately 15 ohms for a 100-volt coil and 5 ohms for a 24-volt coil.

### Using a Diode for Arc Suppression

If it is desirable to delay the disengagement time, a diode should be used (see Schematic 6). For a 100-volt circuit, use a 1N5402 diode with 200 PIV rating, and for a 24-volt circuit, use a 1N5401 diode with a 100 PIV rating.

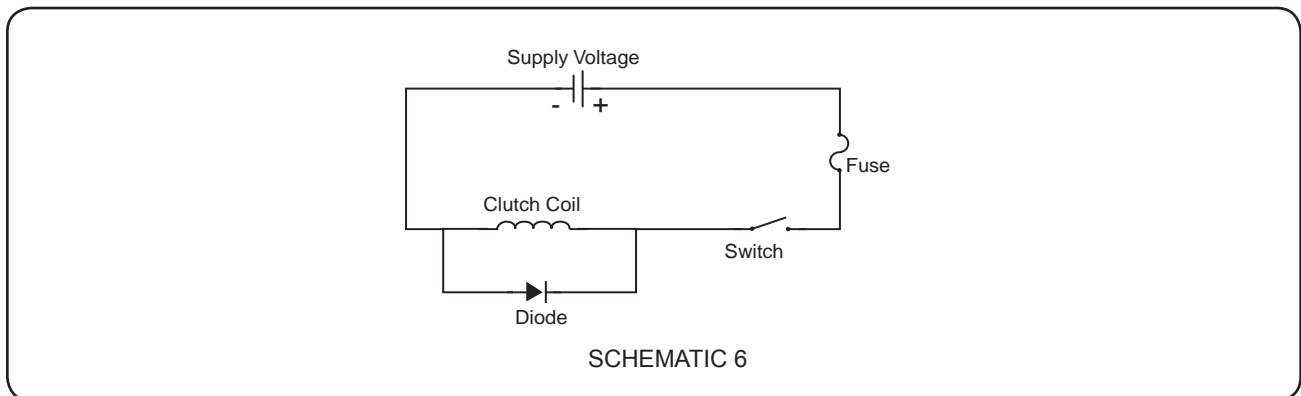

# The Carlyle Johnson Machine Company, LLC

## Model EMA Electric Multi-Disc Clutches

### DESIGN GUIDELINES

#### 4 Operating Parameters

##### 4.1 Torque Ratings

Chart 1 shows the relationship of voltage and static torque for EMA Maxitorq® clutches. Between the engagement voltage (approximately 40% of the rated coil voltage) necessary to overcome the separator springs, and full voltage, the torque characteristics of the clutch are essentially linear.

Chart 1 reflects the static torque handling capability of the EMA clutches. Dynamic torque varies with speed but as a rule of thumb at 1800 RPM it is approximately 50% of static torque. Table 1 shows the full static and dynamic torque at rated voltage and 1800 RPM.

To calculate actual torque required for your application, refer to the formula in Appendix 1

##### 4.2 Engagement / Disengagement Times

Table 2 shows the typical engagement and disengagement times. These times were obtained using a standard Carlyle Johnson Model CEC Power Supply. Modified engagement times are often possible by using a special power supply. Contact the factory for assistance.

##### 4.3 Cycle Rate

The maximum cycle rate is limited by the ability of the clutch to dissipate heat. Table 1 shows the heat dissipation of the family of EMA Maxitorq® clutches running dry.

Heat dissipation is influenced by the inertia of the rotating components; the rotation speed of the clutch; and the cycle rate. Refer to the appropriate formula in Appendix 1, which can be used to calculate the heat generated from clutch cycling.

Once a clutch size has been selected by determining the torque capability of the drive components, it is recommended that the heat dissipation capability of the specified clutch be checked.

##### 4.4 Rotation / Speed

Maxitorq® clutches can rotate in either direction; in addition the driving member can be either the clutch drive cup or the clutch body.

Maximum RPM for standard conditions are shown in Table 1. Contact the factory for additional information about higher speed applications. Carlyle Johnson has experience with rotating components at speeds up to 40,000 RPM.

##### 4.5 Inertia

The data in Table 1 details the inertia of the clutch components. When sizing a clutch for dynamic engagement, inertia of the driving and driven components must be considered. The formulas in Appendix 1 show how to utilize the inertia values of the system to determine the clutch size. If assistance is required to determine system inertia, please contact the factory.

The Carlyle Johnson Machine Company, LLC  
 Model EMA Electric Multi-Disc Clutches

DESIGN GUIDELINES

MODEL EMA ELECTRIC MULTI-DISC CLUTCH  
 STATIC TORQUE vs INPUT VOLTAGE

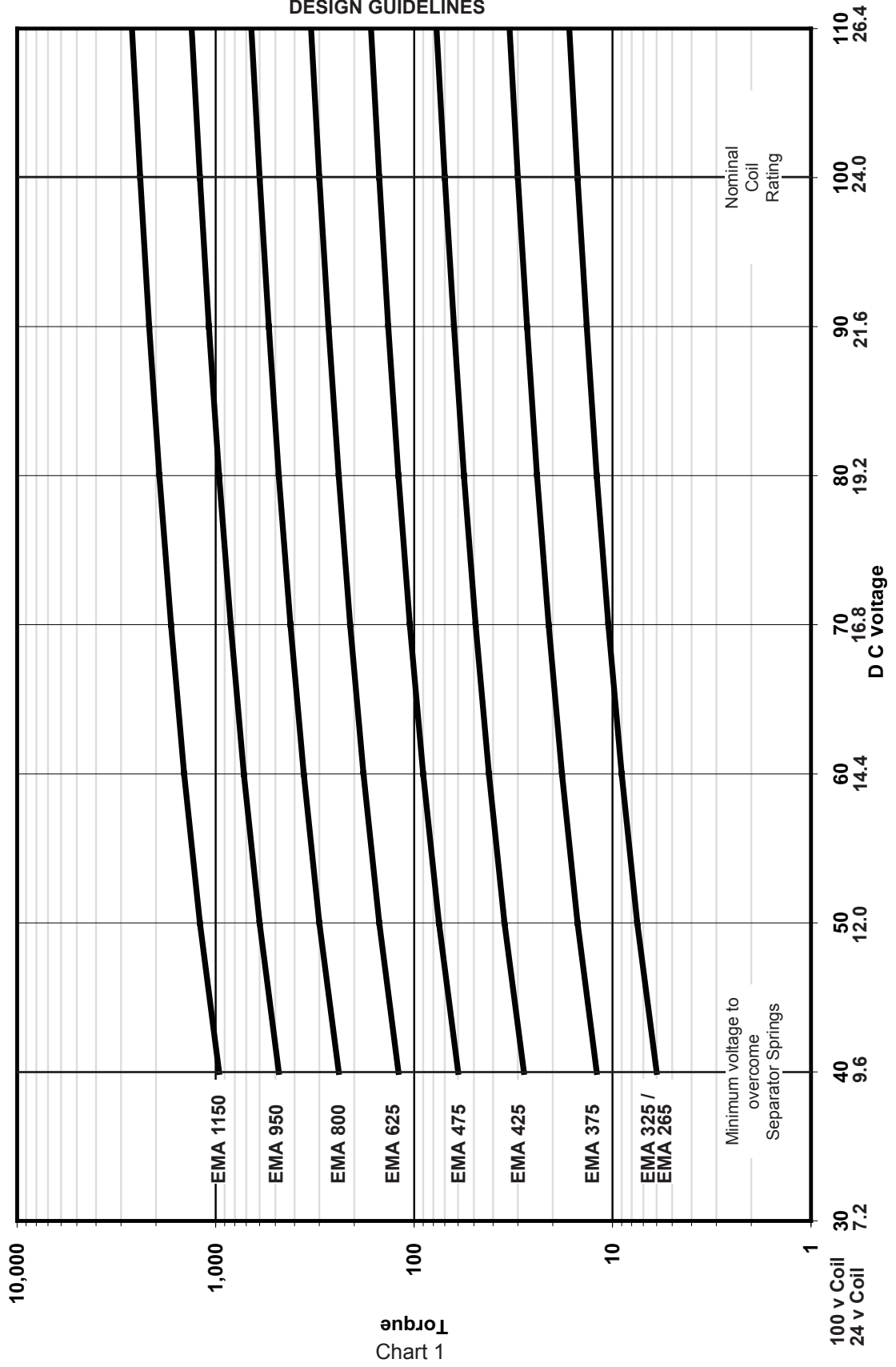

# MODEL EMA ELECTRIC MULTI-DISC CLUTCH MECHANICAL DATA

CLUTCH MODEL	TORQUE (LB-FT)		STANDARD BORE SIZE <sup>2</sup> (in)		AXIAL POSITION (in ± .005)	MAX RPM <sup>3</sup>	TEMP LIMITS (° F)		HEAT DISSIPATION <sup>4</sup> (BTU / MIN)	INERTIA (WR <sup>2</sup> ) (LB-FT <sup>2</sup> )				THEORETICAL BACKLASH	
	DYNAMIC	STATIC	MIN	MAX			COIL	BEARINGS		CLUTCH	OUTER DISCS	INTERNAL FLANGE CUP	EXTERNAL FLANGE CUP	ANGULAR MAXIMUM	RADIAL @ CUP O.D.
EMA0265	8	15	1/2	5/8	0.250	5,000	500°	300°	3.6	0.016	0.003	0.015	0.015	2° 45'	.068"
EMA0325	8	15	1/2	5/8	0.250	5,000	500°	300°	4.0	0.018	0.003	0.018	0.018	2° 39'	.072"
EMA0375	15	35	3/4	7/8	0.250	5,000	500°	300°	5.5	0.030	0.010	0.040	0.040	2° 36'	.095"
EMA0425	36	70	1	1 1/8	0.250	5,000	500°	300°	9.5	0.050	0.015	0.060	0.060	2° 22'	.094"
EMA0475	75	150	1 1/4	1 3/8	0.313	3,600	500°	300°	13.5	0.070	0.020	0.050	0.100	2° 03'	.093"
EMA0625	150	300	1 3/4	1 7/8	0.375	3,600	500°	300°	20.5	0.530	0.070	0.160	0.230	1° 34'	.092"
EMA0800	300	600	2	2 1/4	0.375	3,600	500°	300°	30.0	0.990	0.230	0.430	0.620	1° 16'	.094"
EMA0950	600	1,200	2 3/4	3	0.375	2,500	500°	300°	43.0	2.140	0.460	0.810	1.450	1° 08'	.099"
EMA1150	1,200	2,400	3 1/4	3 1/2	0.375	2,500	500°	300°	57.0	4.690	0.810	1.300	2.600	0° 56'	.095"

Table 1

**NOTES**

- 1 - For clutches run dry
- 2 - Special bore sizes are available - contact factory.
- 3 - Standard applications - see factory for higher speed applications

**MODEL EMA ELECTRIC MULTI-DISC CLUTCH  
ELECTRICAL DATA**

CLUTCH MODEL	24 VOLT DC COIL <sup>3</sup>				100 VOLT DC COIL <sup>3</sup>				COIL INDUCTANCE (mH)	ENGAGEMENT / DISENGAGEMENT <sup>2</sup> (msec)	
	POWER (WATTS)	CURRENT (AMPS)	RESISTANCE ( $\Omega$ )	RECOMMENDED <sup>1</sup> FUSE (AMPS)	POWER (WATTS)	CURRENT (AMPS)	RESISTANCE ( $\Omega$ )	RECOMMENDED <sup>1</sup> FUSE (AMPS)		ENGAGEMENT	DISENGAGEMENT (AT RATED TORQUE)
EMA0265	48	2.0	12	2 1/2	33	0.3	299	1	600	15 - 30	14 - 28
EMA0325	48	2.0	12	2 1/2	49	0.5	204	1	650	20 - 40	15 - 30
EMA0375	40	1.7	15	2 1/2	41	0.4	244	1	750	30 - 50	15 - 30
EMA0425	41	1.7	14	2 1/2	48	0.5	208	1	750	30 - 50	25 - 45
EMA0475	58	2.4	10	3	62	0.6	161	1	750	20 - 50	45 - 65
EMA0625	58	2.4	10	3	64	0.6	157	1	750	70 - 100	45 - 100
EMA0800	68	2.8	9	4	78	0.8	128	1 1/4	1,200	80 - 150	90 - 150
EMA0950	96	4.0	6	5	97	1.0	103	1 1/2	1,450	100 - 150	200 - 300
EMA1150	89	3.7	7	5	115	1.1	87	1 1/2	1,750	150 - 200	500 - 700

**NOTES**

- 1 - Fuses must be able to tolerate an inrush current equal to 135% of their rated value for a minimum of 1 second
- 2 - Times obtained using standard Carlyle Johnson Model CEC Power Supply
- 3 - at 65° F

Table 2

# The Carlyle Johnson Machine Company, LLC

## Model EMA Electric Multi-Disc Clutches

### TYPICAL APPLICATIONS

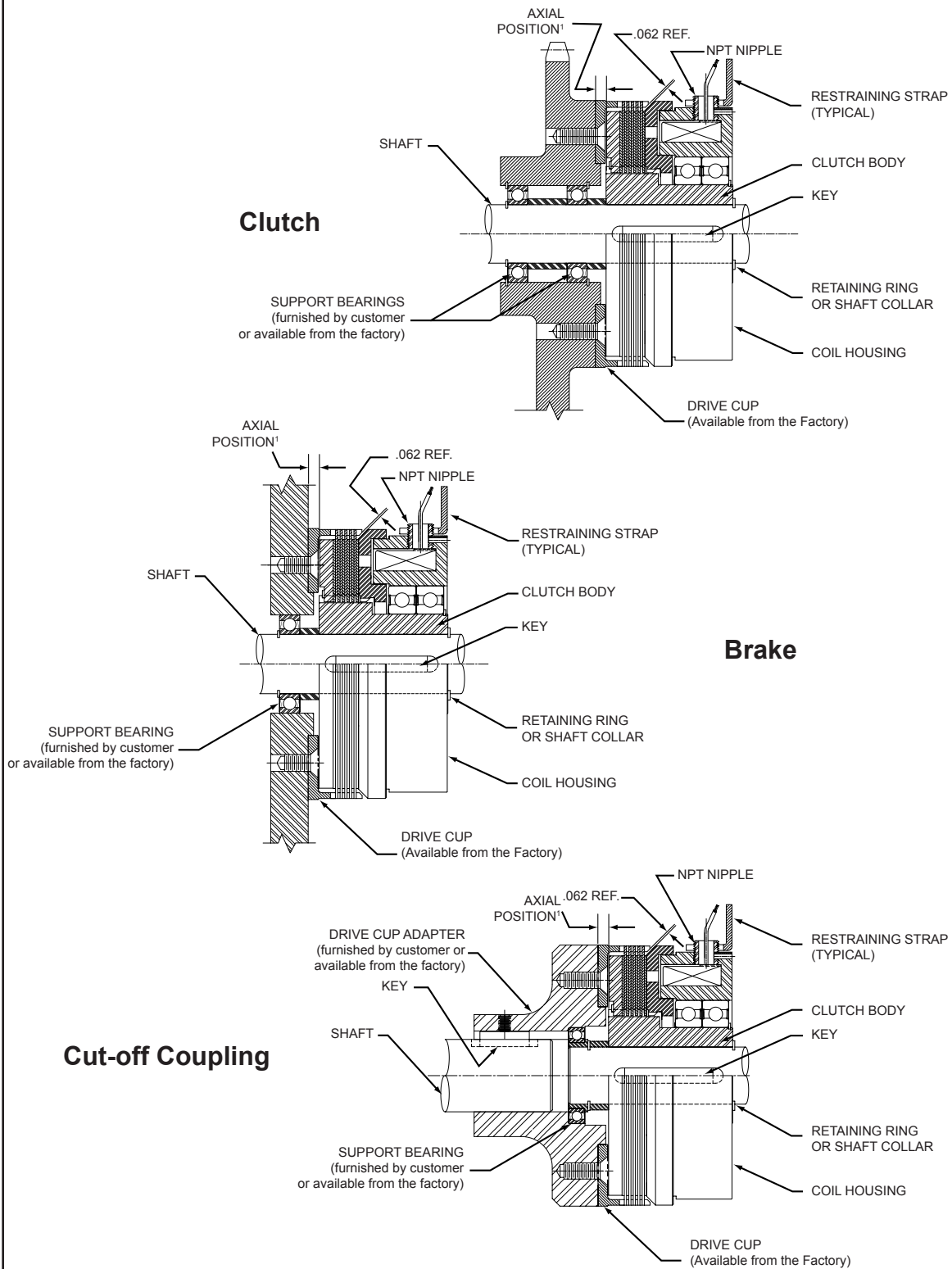

NOTE 1 - See Table 1 for dimensions by clutch model

Figure 1

**The Carlyle Johnson Machine Company, LLC**  
Model EMA Electric Multi-Disc Clutches

**EXPLODED PARTS DIAGRAM - MODEL EMA**

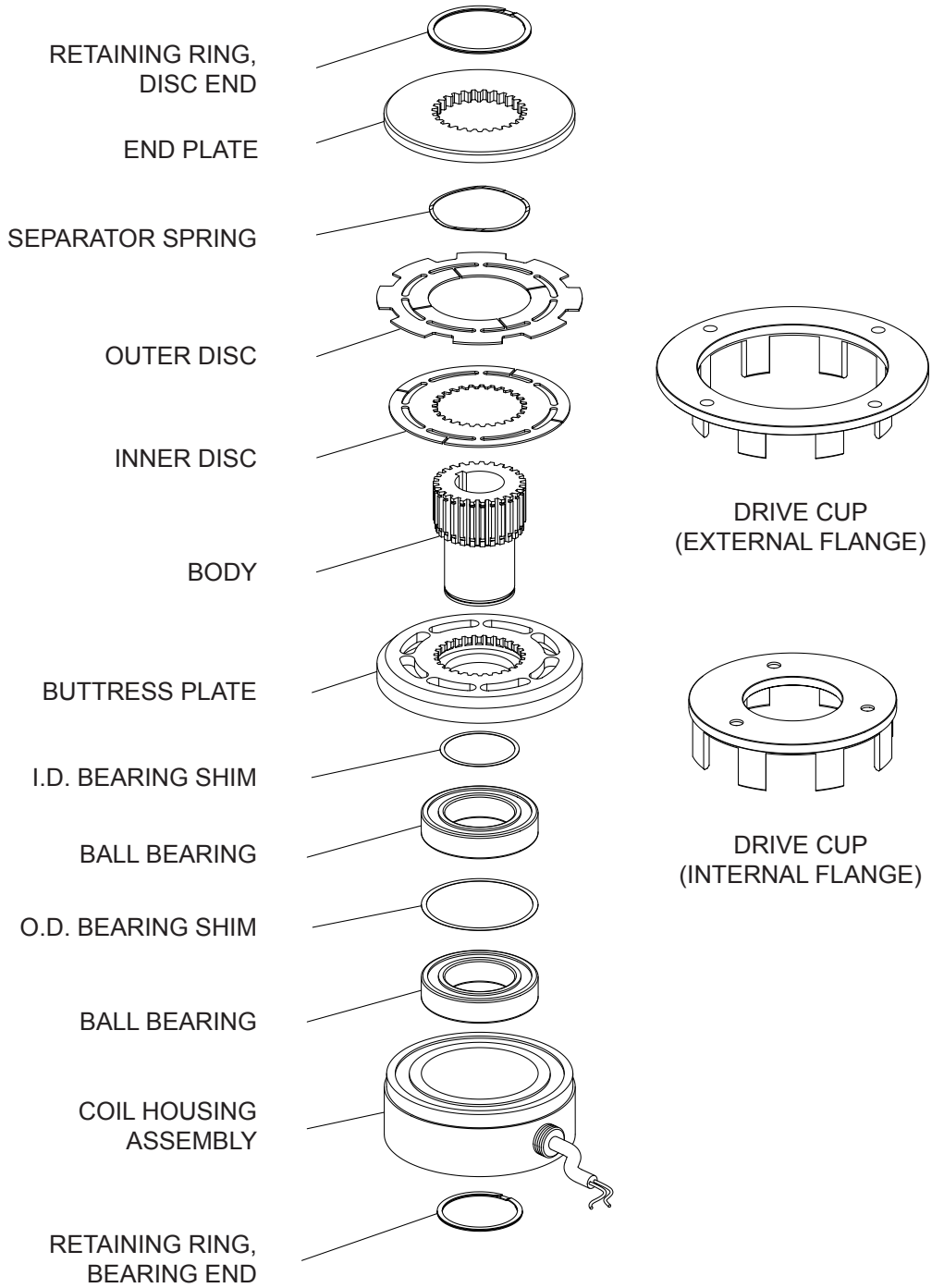

**Figure 2**

# The Carlyle Johnson Machine Company, LLC

## Model EMA Electric Multi-Disc Clutches

### FORMULAS

#### Formula 1 - Torque based on Inertia and Time

$$\text{Dynamic Torque}_{\text{ave}} = \frac{(WR^2) (\Delta N)}{308(t)}$$

Dynamic Torque is expressed in (lb ft)

N = Speed (RPM)

( $\Delta N$ ) =  $N_i - N_o$  where  $N_i$  = Input speed;  $N_o$  = Output speed

( $WR^2$ ) = Inertia (lb ft<sup>2</sup>) of the clutch and system

( $WR^2$ ) = ( $WR^2_{\text{system}}$ ) + ( $WR^2_{\text{clutch components}}$ )

t = time (sec)

**See Appendix 2 for sample calculations.**

#### Formula 2 - Torque based on Drive Components

$$\text{Torque}_{\text{ave}} = \frac{(5250) (HP) (K_f)}{N_R}$$

Torque is expressed in (lb ft)

HP = Horsepower

( $K_f$ ) = Safety factor

$N_R$  = Running speed (RPM)

**See Appendix 2 for sample calculations.**

#### Formula 3 - Formula for determining Heat Load

$$E = \text{BTU}/_{\text{min}} = \frac{1.7 (WR^2) (\text{RPM} / 100)^2 (\text{Engagements per Minute})}{780}$$

$E = \text{BTU}/_{\text{min}} = \text{Heat load}$   
( $WR^2$ ) = Inertia

**See Appendix 2 for sample calculations.**



# The Carlyle Johnson Machine Company, LLC

Model EMA Electric Multi-Disc Clutches

## SAMPLE CALCULATIONS

### Formula 1 - Torque based on Inertia and Time

Example 1: Torque required to accelerate an inertia load of 5 lb ft<sup>2</sup> from rest to 1,800 RPM in 0.5 seconds:

Start with a rough approximation of the dynamic torque using the formula:  $((5.00 * 1800) / (308 * .5)) = 58.44$  lb ft dynamic torque, requiring an EMA0475, based on the table "Mechanical Data")

$(\Delta N) = 1800$  (accelerate from 0 to 1,800 RPM)

$(WR^2) = (WR^2_{\text{system}}) + (WR^2_{\text{clutch components}}) = 5 \text{ lb ft}^2 + .14 \text{ lb ft}^2 \text{ (Model EMA0475)} = 5.14 \text{ lb ft}^2$   
 $t = .5 \text{ sec}$

$$\text{Dynamic Torque}_{\text{ave}} = \frac{(WR^2) (\Delta N)}{308(t)} = \frac{(5.14) (1800)}{308(.5)} = \frac{9252}{154} = 60.08 \text{ lb ft}$$

**Model EMA0475 with a dynamic torque rating of 75 lb ft is the appropriate selection.**

### Formula 2 - Torque based on Drive Components

Example 2: Torque output of a 10 HP motor at 1,800 RPM with a clutch attached directly to the motor shaft:

HP = 10.0

$(K_f) = 1.0$  (for electric motors. Use 2.0 for internal combustion engines)

$N_R = 1,800$  RPM

$$\text{Torque}_{\text{ave}} = \frac{(5250) (\text{HP}) (K_f)}{N_R} = \frac{(5250) (10.0) (1.0)}{1800} = 29.17 \text{ lb ft}$$

**Model EMA0425 with a dynamic torque rating of 36 lb ft is the appropriate selection.**

### Formula 3 - Formula for determining Heat Load

Example 3: Using the data from Example 1, determine the heat load with a cycle rate of 4 engagements per minute:

$$E = \text{BTU}/_{\text{min}} = \frac{1.7 (WR^2) (\text{RPM} / 100)^2 (\text{Engagements per Minute})}{780} = \frac{1.7 (5.14) (1800 / 100)^2 (4)}{780}$$
$$= \frac{11324.45}{780} = 14.52 \text{ BTU}/_{\text{min}}$$

**Model EMA0625 has the necessary heat dissipation rate to handle this application.  
Even though Model EMA0475 can handle the torque, the larger clutch is required due to heat load.**

# The Carlyle Johnson Machine Company, LLC

Model EMA Electric Multi-Disc Clutches

## DESIGN GUIDELINES

### INERTIA OF STEEL BARS, SHAFTS, OR DISCS (per inch of length or thickness)

DIA (in)	R <sup>2</sup>	Weight per inch	WR <sup>2</sup> (lb ft <sup>2</sup> )		DIA (in)	R <sup>2</sup>	Weight per inch	WR <sup>2</sup> (lb ft <sup>2</sup> )
3/4	0.00049	0.1252	0.00006		22	0.42014	107.6900	45.245
1	0.00087	0.2225	0.0002		23	0.45920	117.7025	54.049
1 1/4	0.00136	0.3477	0.000		24	0.50000	128.1600	64.080
1 1/2	0.0020	0.5006	0.001		25	0.5425	139.0625	75.446
1 3/4	0.0027	0.6814	0.002		26	0.5868	150.4100	88.261
2	0.0035	0.8900	0.003		27	0.6328	162.2025	102.644
2 1/4	0.0044	1.1264	0.005		28	0.6806	174.4400	118.716
2 1/2	0.0054	1.3906	0.008		29	0.7300	187.1225	136.606
2 3/4	0.0066	1.6827	0.011		30	0.7813	200.2500	156.445
3	0.0078	2.0025	0.016		31	0.8342	213.8225	178.371
3 1/4	0.0092	2.3502	0.022		32	0.8889	227.8400	202.524
3 1/2	0.0106	2.7256	0.029		33	0.9453	242.3025	229.052
3 3/4	0.0122	3.1289	0.038		34	1.0035	257.2100	258.103
4	0.0139	3.5600	0.049		35	1.0634	272.5625	289.834
4 1/4	0.0157	4.0189	0.063		36	1.1250	288.3600	324.405
4 1/2	0.0176	4.5056	0.079		37	1.1884	304.6025	361.980
4 3/4	0.0196	5.0202	0.098		38	1.2535	321.2900	402.728
5	0.0217	5.5625	0.121		39	1.3203	338.4225	446.823
5 1/2	0.0263	6.7306	0.177		40	1.3889	356.0000	494.444
6	0.0313	8.0100	0.250		41	1.4592	374.0225	545.774
6 1/2	0.0367	9.4006	0.345		42	1.5313	392.4900	601.000
7	0.0425	10.9025	0.464		43	1.6050	411.4025	660.315
7 1/2	0.0488	12.5156	0.611		44	1.6806	430.7600	723.916
8	0.0556	14.2400	0.791		45	1.7578	450.5625	792.004
8 1/2	0.0627	16.0756	1.008		46	1.8368	470.8100	864.786
9	0.0703	18.0225	1.267		47	1.9175	491.5025	942.473
9 1/2	0.0783	20.0806	1.573		48	2.0000	512.6400	1025.280
10	0.0868	22.2500	1.931		49	2.0842	534.2225	1113.427
11	0.1050	26.9225	2.828		50	2.1701	556.2500	1207.140
12	0.1250	32.0400	4.005		51	2.2578	578.7225	1306.647
13	0.1467	37.6025	5.516		52	2.3472	601.6400	1412.183
14	0.1701	43.6100	7.420		53	2.4384	625.0025	1523.986
15	0.1953	50.0625	9.778		54	2.5313	648.8100	1642.300
16	0.2222	56.9600	12.658		55	2.6259	673.0625	1767.373
17	0.2509	64.3025	16.131		56	2.7222	697.7600	1899.458
18	0.2813	72.0900	20.275		57	2.8203	722.9025	2038.811
19	0.3134	80.3225	25.171		58	2.9201	748.4900	2185.695
20	0.3472	89.0000	30.903		59	3.0217	774.5225	2340.376
21	0.3828	98.1225	37.563		60	3.1250	801.0000	2503.125

For calculating sizes not shown, and for other common materials, see formulas in Appendix 4

# The Carlyle Johnson Machine Company, LLC

Model EMA Electric Multi-Disc Clutches

## DESIGN GUIDELINES

### OTHER USEFUL FORMULAS - TORQUE and INERTIA

#### Torque Calculation for Electric Motors

Torque (lb-in) based on HP and RPM:  $T = \frac{HP \times 63025}{\text{Motor RPM}}$

Torque (lb-ft) based on HP and RPM:  $T = \frac{HP \times 5250}{\text{Motor RPM}}$

#### Horsepower of Rotating Objects

$$HP = \frac{\text{Torque (lb ft)} \times \text{Shaft Speed (RPM)}}{5250}$$

#### Horsepower of Objects in Linear Motion

$$HP = \frac{\text{Force (lb)} \times \text{Velocity (fpm)}}{33000}$$

#### Inertia of Bars, Shafts, or Discs

Weight of bar/shaft/disc (in pounds):

$wt = f \times r^2$   $r = \text{radius (inches)}$

$f = \text{factor (see below)}$

Radius of gyration for a cylinder:  $R^2 = (1/2) \times (r/12)^2$

$r = \text{radius (inches)}$

Inertia per inch of length:  $WR^2 = (wt) \times (R^2)$

#### Weight Factor per Inch of Various Materials (lbs)

Steel	$f = .890$
Rubber	$f = .108$
Nylon	$f = .161$
Aluminum	$f = .310$
Bronze	$f = 1.010$
Cast Iron	$f = .821$

#### To Calculate the Inertia per inch of length for a Hollow Cylinder:

Subtract the  $WR^2$  of the I.D. from the  $WR^2$  of the O.D.

# The Carlyle Johnson Machine Company, LLC

## Model EMA Electric Multi-Disc Clutches

### DESIGN GUIDELINES

#### OTHER USEFUL FORMULAS - TORQUE and INERTIA

##### Reflected Inertia (Rotating devices)

Inertia calculations used to determine the proper size for a clutch or brake must take into account the ratio of the speed (in RPM) of the clutch and the speed (in RPM) of the other elements in the system. While horsepower is essentially unchanged throughout the system, inertia scales up or down proportionally in relation to rotating speed.

$$\text{Inertia at Clutch:} \quad WR^2_{\text{at clutch}} = WR^2_{\text{at source}} \times \frac{\text{RPM}_{\text{at source}}}{\text{RPM}_{\text{at clutch}}}$$

##### Reflected Inertia (Linear devices)

Inertia calculations used to determine the proper size for a clutch or brake must take into account the load presented to the clutch from any linear devices being driven (such as a conveyor). This load can be reduced to an equivalent inertia value using the formula below. The critical information which must be determined is (1) the weight of the load; and (2) the diameter of the driving pulley, sprocket, gear, or drum.

$$\text{Inertia of Load:} \quad WR^2_{\text{load}} = \text{Weight (lbs)}_{\text{load}} \times \left( \frac{\text{DIA}_{\text{ft}}}{2} \right)^2$$

Using the rotating device formula above, the inertia at the clutch can be calculated:

$$\text{Inertia at Clutch:} \quad WR^2_{\text{at clutch}} = WR^2_{\text{load}} \times \frac{\text{RPM}_{\text{driving device}}}{\text{RPM}_{\text{at clutch}}}$$

**The Carlyle Johnson Machine Company, LLC**  
Model EMA Electric Multi-Disc Clutches

NOTES

